

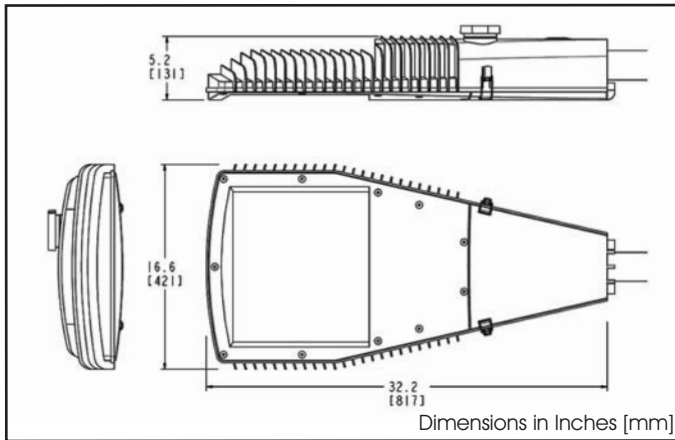

Patent Pending

## StreetSENSE™ SL Series LED Street Light



*A new direction in roadway lighting.*

The essentials of good road lighting never change, but in a world where energy efficiency and reliability are becoming increasingly important, the Dialight - StreetSENSE introduces a new direction in roadway lighting. Integrating intelligence, the latest LED technology and ease of installation, Dialight provides a roadway lighting solution with enviable cost of ownership.

All of Dialight's long life LED luminaires are designed to meet the most demanding specification criteria while offering maximum energy savings, reduced maintenance costs, and a superior quality of light.

### Certifications & Ratings:

- ▷ UL1598
- ▷ CSA 22.2 # 250
- ▷ IP66 (pending)

### Test Reports:

- ▷ LM-79
- ▷ LM-80

### Compliances:

- ▷ RP-8-00

### Features & Benefits:

- ▷ Low power consumption
- ▷ Instant on/off response
- ▷ Mercury free
- ▷ Resistant to shock and vibration
- ▷ 70% lumen maintenance over 60,000 operating hours

### Order Codes:

Part Number	LED Drive Current (mA)	Total System Power Consumption (W)	Initial Fixture Lumens	LM-79	LM-80
SL2C4ELGH	315	131	6581	√	√
SL2C4BLGH	315	65	3489	√	√

### Mechanical Information:

- Fixture Weight:** <39 lbs (sandcast version)
- Mounting:** Accommodates a 2" IP (2.375" OD) pipe. Provision for adjustment of +/-5° in 2.5° increments
- Vibration Resistance:** ANSI C136.31

### Electrical specifications:

- Operating Voltage:** **Standard:** 100-277V (+10/-20%)  
**Optional:** 347-480V nominal (+10/-20%)

- Total System Power Consumption:** See Ordering Info below

- Operating Temp:** -40°C to 74°C (-40°F to 165°F);  
With built-in thermal overload protection circuitry

- Noise Requirements / EMC:** FCC Title 47, Subpart B, Section 15, class A device. RF Immunity; 10V/m, 80MHz-1GHz

- Transient Protection:** ANSI C136.2 (600V classification)- Dielectric and Transient voltage withstand tests

- THD:**  
<5% (120VAC)  
<10% (230/240VAC)  
<12% (277VAC)

- Power Factor:** >0.95

### Material:

- Housing:** Cast aluminum housing with terminal block for up to 6AWG wire. Unique hinged grey polycarbonate bottom cover provides tool less access to terminal blocks and pipe fittings for quick luminaire mounting.

- Finish:** Polyester powder coat grey. Standard RAL 7035.  
(Other finish options available on request.)

- Lens:** UV and abrasion resistant polycarbonate cover lens  
(Glass lens options available on request.)

- Photocontroller Socket:** Standard NEMA three prong twist lock, socket with shorting cap, as per ANSI C136.10

- Photocontroller:** Optional (ordered separately)

### Photometric Information:

- CRI (typ):** 70

- CCT (typ):** 6000K (cool white)  
(Other color options available on request)

- Optics:** IES Type II; Dark sky Compliant Full cut-off fixture.  
(Other Types available on request)

# SL2C4ELGH - Light Measurement Data

Iso-Illuminance Chart (fc)

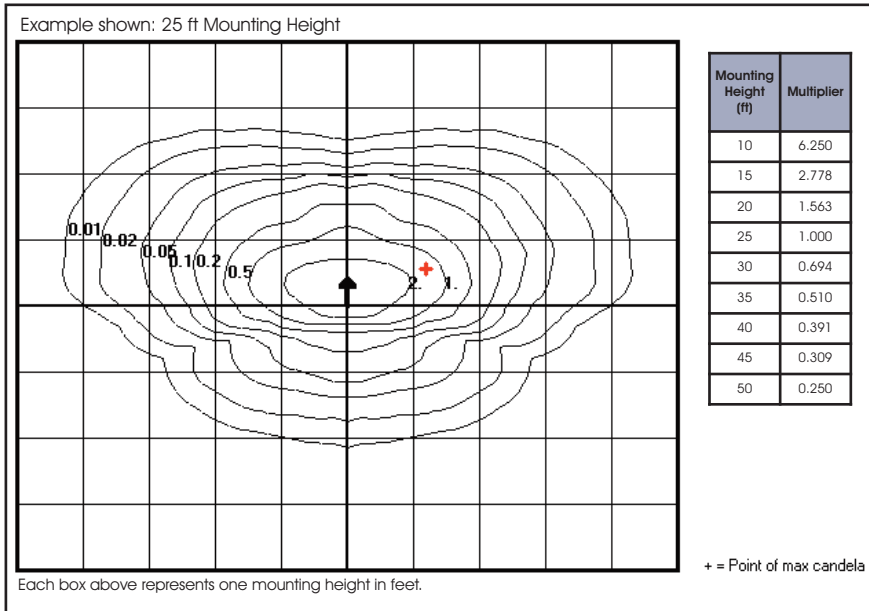

Intensity Distribution Curve (cd)

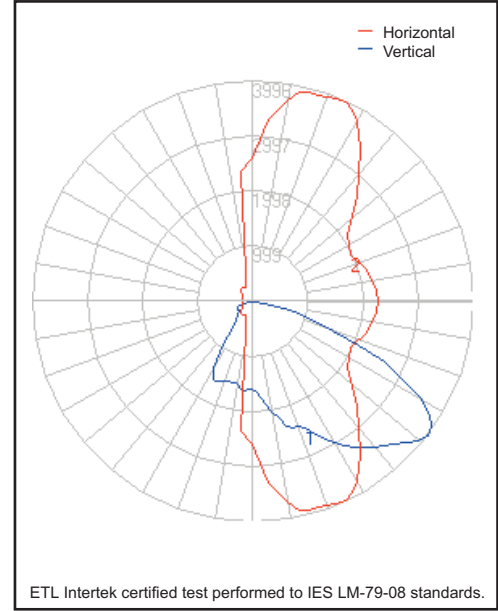

IESNA RP-8-00 Compliant

# SL2C4BLGH - Light Measurement Data

Iso-Illuminance Chart (fc)

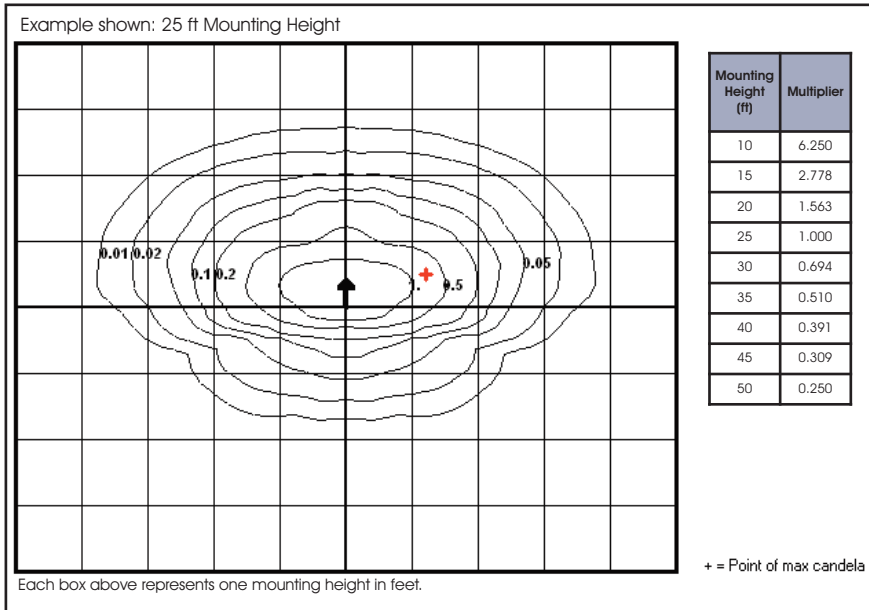

Intensity Distribution Curve (cd)

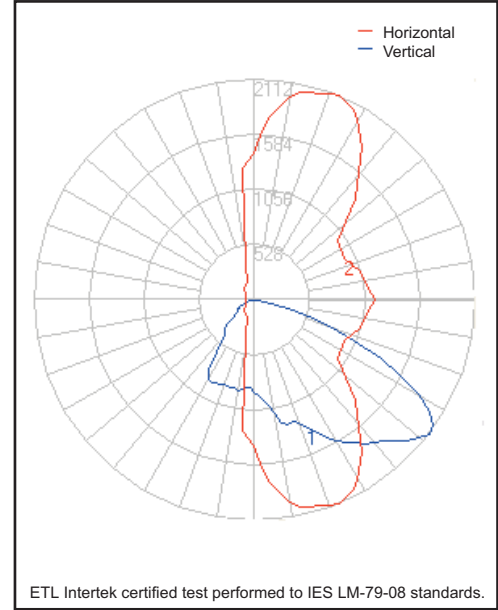

IESNA RP-8-00 Compliant

The most current version of this document will always be available at:  
[www.dialight.com/Assets/Brochures\\_And\\_Catalogs/Illumination/MDEXSTSSLX001](http://www.dialight.com/Assets/Brochures_And_Catalogs/Illumination/MDEXSTSSLX001)

IES files and other photometric data available upon request.

MDEXSTSSLX001\_B